

Experimental studies on the suitability of human mesothelial cells for seeding vascular prostheses: shear stress resistance *in vitro*

F. BITTINGER*, S. MÜHLBAYER†, V. SALIH§, M. GRAU‡, H. A. RICHTER‡, C. L. KLEIN*, C. J. KIRKPATRICK*

*Institute of Pathology, Johannes Gutenberg University of Mainz, Germany

‡Institute of Pathology, Technical University of Aachen (RWTH), Germany

§Department of Experimental Pathology, The Institute of Orthopaedics, Stanmore, UK

This investigation forms part of a study on the suitability of human omentum mesothelial cells (HOMES) as an alternative to endothelial cells (EC) for seeding vascular grafts. Isolated HOMES were grown in primary culture and characterized by their morphology (light microscopy and scanning electron microscopy (SEM)), as well as by fluorescence-activated cell sorting (FACS) and immunocytochemistry. The latter two methods showed cells which were positive for smooth muscle-type actin and cytokeratin, but negative for factor VIII-related antigen. HOMES were grown to confluence on glass with or without a fibronectin coating. Controlled shear stress was applied for up to 30 min using a plate and cone rheometer at 20 dynes/cm². These dynamic culture conditions led to loss of only occasional cells. The most marked alterations seen on SEM were some cell elongation, marked raising of the nucleus and loss of luminal cytoplasmic microvilli. Time-lapse video microscopy revealed that shear stress also increased the spreading capacity of some cells. Similar experiments with venous endothelial cells gave a shearing off of a confluent monolayer. This investigation shows the marked shear-stress resistance of HOMES, a pre-requisite for their use to seed vascular prostheses.

1. Introduction

Despite the major advances in understanding the complex pathobiology of atherosclerosis, the treatment of severe cases remains the replacement of severely diseased arterial segments by vascular prostheses. A further advance in treatment regimens is to use the patient's own endothelial cells (EC) to seed on to the luminal surface of the prosthesis to provide a more hemocompatible surface [1,2]. As a result of the poor growth substratum of the synthetic materials used, numerous attempts have been made to improve the adhesion of EC to the synthetic lumen. The types of modification procedure, as well as the problems associated with them have been reviewed by Kirkpatrick *et al.* [3]. A critical study of the use of EC pre-seeding techniques shows that, although the methodology is successful in several animal models, such as in the dog and even the baboon [4-6], the long-term patency of such prostheses in humans is disappointing [7].

Such seeding techniques usually require EC isolation from a medium-sized vein, such as the saphenous vein in the leg. However, some surgeons are reluctant to sacrifice such veins, in case they are needed for

coronary bypass surgery at a later date. This has led to a search for other sources of EC or other suitable cell types for seeding. Human fat tissue from the abdominal cavity (omentum) offers a source of microvascular EC, although one of the principal publications on this methodology describes a method which does not yield a pure population of EC [8], but a mixture of endothelial and mesothelial cells. The mesothelial nature of these cultured cells has been clearly shown by various groups using immunocytochemical markers, as well as ultrastructural characteristics [9-14].

We have been interested in the feasibility of using mesothelial cells, instead of EC, for seeding of vascular prostheses. This is regarded as biologically tenable, as both cell types derive from a primitive mesenchymal stem cell. This paper presents a method for isolation and characterization of human omentum mesothelial cells (HOMES) and describes their reaction under shear stress conditions when grown on a synthetic substrate. This forms part of a project to test the hypothesis that mesothelial cells can adopt an endothelial phenotype when subjected to optimal flow conditions. The presentation shows that under the experimental rheological conditions tested (plate and cone

rheometer) confluent monolayers of HOMES, but not human umbilical vein endothelial cells (HUVEC) used as control, are essentially preserved.

2. Materials and methods

2.1. Isolation of HOMES

Human omental adipose tissue was obtained at abdominal surgery and transported in sterile balanced salt solution to the laboratory. Within 3 h of removal of the tissue, approximately 20 g of tissue were shaken under sterile conditions for 5 min with 30 ml of 0.05% trypsin (Trypsin, Type III salt-free, Sigma, Germany). The supernatant was then removed and added to 60 ml of Ham's F-12/Iscove's medium (HIM) (Gibco, Germany 50:50 v/v), containing 20% fetal calf serum (FCS, Gibco). This solution was centrifuged for 10 min at 173 g and the pellet resuspended in 5 ml of phosphate-buffered saline (PBS-Dulbecco's, Gibco), containing 1% bovine serum albumin (BSA, Sigma) and layered over 45% Percoll (Pharmacia, Sweden). Following centrifugation for 10 min at 500 g, the HOMES layer was removed and washed three times with PBS/BSA. The cells were then seeded at a density of 3×10^5 cells/ml in HIM + 20% FCS into 75 cm² culture flasks. Incubation took place at 37 °C in a humidified atmosphere of 5% CO₂ in air.

2.2. Characterization of HOMES

The cells isolated as described above were characterized by light microscopy, immunocytochemistry, fluorescence-activated cell sorting (FACS) and scanning electron microscopy (SEM). All studies were performed on the primary culture.

Cells grown on sterile glass coverslips were fixed for 7 min in methanol at -20 °C and stained with haematoxylin and eosin. Immunofluorescence was performed on cultures also fixed for 7 min in absolute methanol at -20 °C.

Flow cytometric analysis was carried out with the assistance of a FACScan (Becton-Dickinson, Mountain View, CA). The cells were fixed for 1 h in 4% (vol/vol) paraformaldehyde at 4 °C and permeabilized with 0.1% (vol/vol) triton-X 100 in PBS. Subsequently, cells were incubated for 45 min with a primary antibody, anti-cytokeratin (AE1/AE3, Boehringer, Mannheim, Germany) or anti-actin (Progen Biotechnik GmbH, Germany) or anti-factor VIII (Dako Diagnostika GmbH, Hamburg, Germany). This initial treatment was followed by incubation with a FITC-labelled anti-mouse F(ab')₂ antibody (Boehringer). Fluorescence was measured using a 515–530 nm band filter.

2.3. HUVEC Cultures

As control population, human umbilical vein endothelial cells (HUVEC) were taken. Their isolation and characterization have been described in detail previously [15]. HUVEC were prepared for shear stress in an identical fashion to that for HOMES (see below).

2.4. Shear stress *in vitro*

Shear stress was studied using a modification of the plate and cone rheometer system, described by Franke *et al.* [16]. This is shown schematically in Fig. 1. The rheometer chamber is fixed between the light source and objective lens of a conventional light microscope (Leitz Fluovert FS), with both cone and plate made of glass to permit continuous microscopic observation and video recording using transmitted light. The cone-plate configuration involves an angle of less than 3 degrees and is fitted with a cone drive which allows constant rotational velocities from very low rotations (10) up to 2400 rpm. The entire rheometer is enclosed in a plexiglass climatic box to enable constant temperature (37 °C) and defined atmospheric conditions (5% CO₂ in air) to be achieved (Fig. 2).

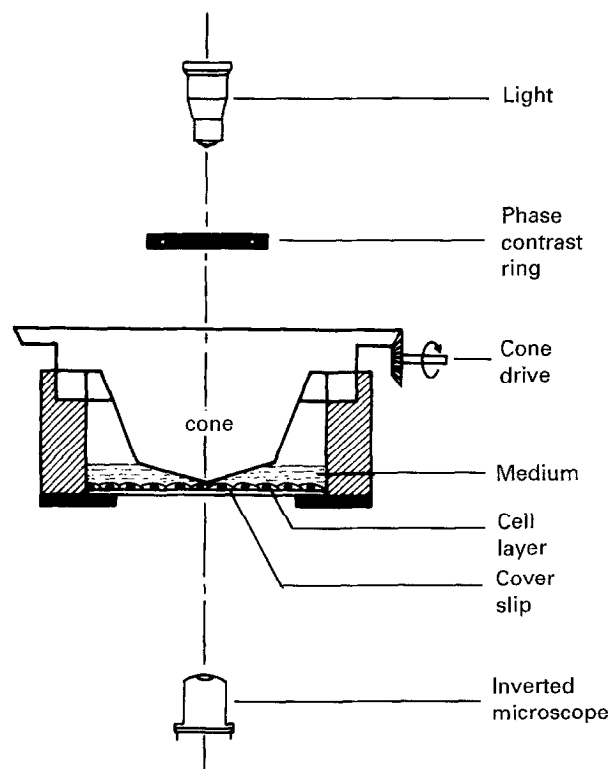

Figure 1 Schematic diagram to illustrate the configuration of the plate and cone rheometer system.

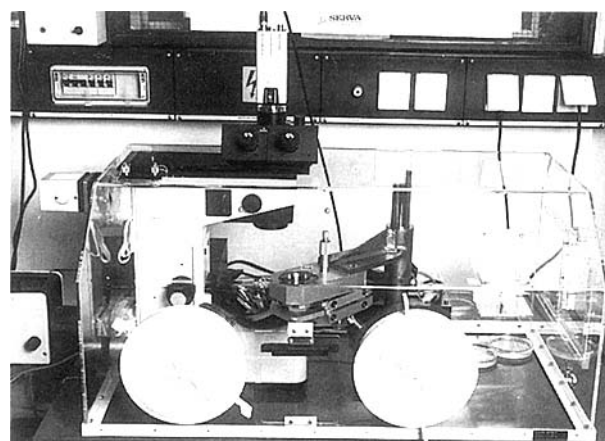

Figure 2 Actual experimental setup of the plate and cone rheometer to illustrate the integration into an inverted microscope system as well as a climatic box.

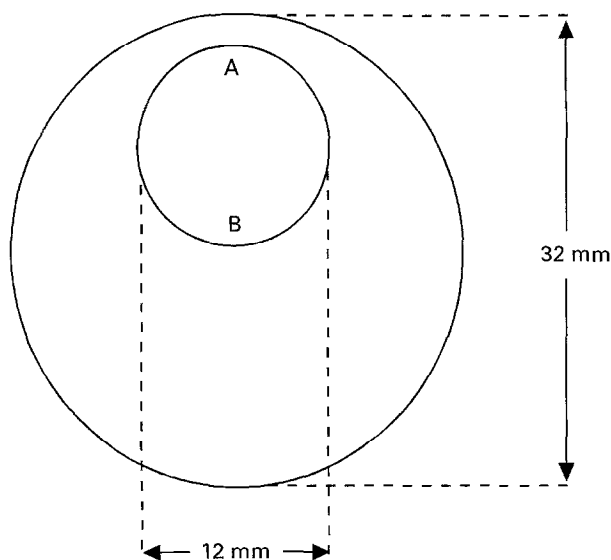

Figure 3 Schematic diagram to show sample preparation for SEM. The outer circle represents the cell-seeded glass plate from the shear experiments. The inner circle represents the laser-cut disc for SEM examination. The asymmetrical positioning enables evaluation of both peripherally (A) and centrally (B) placed cell regions.

For the shear stress experiments HOMES were seeded at a density of 10^6 cells/well on to sterile circular glass slides (32 mm diameter, Firma Faust, Aachen), placed in 6-multiwell tissue culture plates (35 mm diameter, Becton Dickinson GmbH, Germany). The growth medium was HIM + 20% FCS. Some cultures were prepared on fibronectin-coated (FN) glass by exposing the glass surface overnight to an aqueous solution of FN (5 $\mu\text{g}/\text{ml}$, Sigma) in PBS. After confluence was reached, the monolayers were thoroughly washed in serum-free medium and finally covered by 370 μl of serum-free HIM after transferal to the chamber of the rheometer. HOMES monolayers were subjected to shear stress of 2 Pa, which is equivalent to that in the human femoral artery *in vivo*. This was applied suddenly and for periods of up to 30 min.

Time-lapse video microscopy was conducted on some cultures for the entire 30 min period. Samples for SEM were taken at three time periods; 5, 15 and 30 min. Cultures were fixed in 2.5% cacodylate-buffered (0.1 mol/l) glutaraldehyde (pH 7.5) at room temperature, dehydrated in an ascending ethanol series and air dried. The 32 mm HOMES-seeded glass substratum was then cut with a CO_2 laser to give a circular disc of 12 mm diameter. The location of this smaller disc is shown in Fig. 3. This cutting procedure was started 5 mm from the peripheral edge of the large glass disc and resulted in a smaller disc containing both peripheral (A) and central (B) regions of the original sheared monolayer.

3. Results and discussion

3.1. Characterization of HOMES

The isolated cells from the omental fat tissue grew readily to form confluent monolayers consisting of polygonal shaped cells. Using FACS it could be shown that the cells did not express factor VIII RA

(Fig. 4b), giving a fluorescence one height trace similar to the negative control (Fig. 4a), which had no primary antibody, but just the fluorescein-coupled second antibody. By comparison, both smooth muscle actin and a cytokeratin, the latter recognizing both epithelial and mesothelial cells, gave definite specific peaks (Fig. 4c and d).

The reactions described by FACS analysis were confirmed by direct morphological study using immunocytochemistry. Fig. 5a shows a marked immunofluorescent signal for cytokeratin. Whereas differences in staining intensity were seen from cell to cell, no cells were seen which were negative for cytokeratin. This underlines the purity of the cultures. It should be stressed that endothelial cells, whether from the omentum microvasculature or from the human umbilical vein are negative for this cytokeratin. Further characterization was possible by SEM, which revealed cells of approximately 30–50 μm diameter. Fig. 5b demonstrates the characteristic cobblestone morphology of HOMES, a feature which is, however, shared by endothelial cells. Nevertheless, SEM also revealed characteristics not shown by EC, namely the presence of numerous microvilli on the surface of HOMES (Fig. 5c). A further finding was the occasional presence of multinucleated giant cells (Fig. 5d), indicative of the macrophage-related behaviour of this cell type.

From the literature it is evident that mesothelial cell cultures are often part of a mixed culture as a result of attempts to cultivate microvascular endothelial cells from omental fat tissue [9, 12, 13]. Latron *et al.* [13] used monoclonal antibodies to show that in their cultures 10% of cells were EC and approximately 60% MES. Our HOMES characterization indicates that we have more than 95% purity, as shown by cytokeratin staining.

Fig. 6 illustrates the SEM appearance of the peripheral edge of the 12 mm diameter laser-cut disc and shows that this procedure causes no artificial retraction of the cells, but merely a brighter SEM appearance of the cells. This latter change was confined to a rim at the disc periphery of approximately 90–100 μm .

Shear stress, applied suddenly at 20 dynes/cm² did not lead to shearing off of the HOMES monolayer during the 30 min period of study. Time-lapse video microscopy showed that only occasional cells were sheared off the substratum. No differences were evident between fibronectin coating and the non-coated glass surface. Morphological changes were, however, seen on SEM at the various time periods studied, as well as between peripheral and central regions of the sheared monolayer. In general, central regions, that is, those around the centre of the cone, presented the most marked structural alterations. Fig. 7a shows that after 5 min of shear stress cells were still polygonal and for the most part flat. At the same time, central regions of the monolayer contained mesothelial cells with partially raised nuclei and some peripheral cytoplasmic retraction (Fig. 7b). Morphological changes became more marked with time, so that after 15 min of shear stress, cellular elongation became apparent, especially

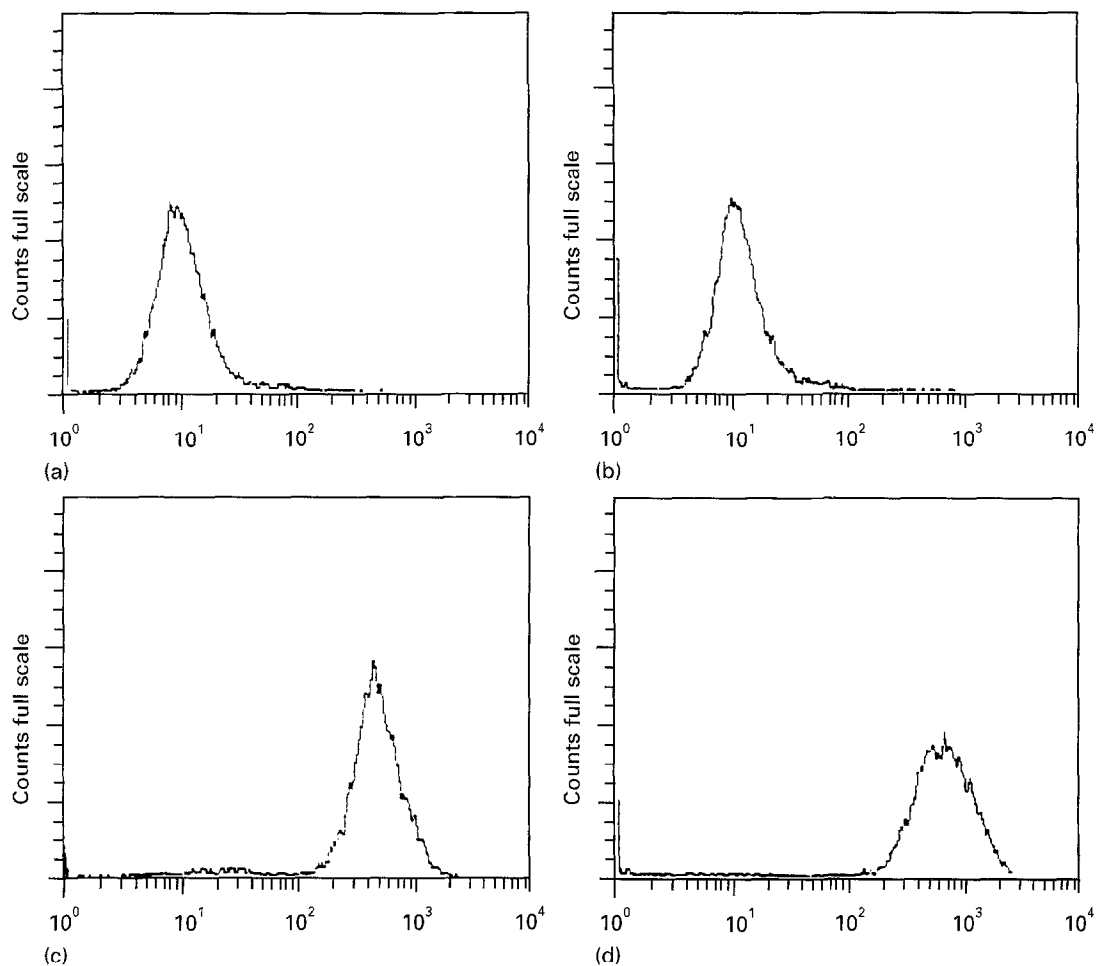

Figure 4 FACS analysis of the isolated mesothelial cells (HOMES) to differentiate them from endothelial cells. (a) Control scan, (b) factor VIII related antigen; (c) actin; (d) cytokeratin. Graphs show counts distribution against fluorescence one height signal in a logarithmic mode. Factor VIII RA gives a curve similar to the control with no peak to the right, indicating no specific fluorescence. Actin and cytokeratin both yield a single peak to the right, indicating a specific fluorescence signal.

in peripheral regions (Fig. 7c). Fig. 7d illustrates a typical central region after the maximum shear stress time of 30 min. As well as marked nuclear elevation and cytoplasmic retraction, HOMES gave evidence of loss of microvilli.

As expected in primary culture systems, some biological variation was apparent in the time course of morphological changes. Thus, in some HOMES cultures cell elongation and cytoplasmic retraction was observed even after 5 min of shear stress (Fig. 8a and b). More marked morphological changes were observed at 15 min, with clearly observed cell elongation (Fig. 8c and d). A high power view, such as in Fig. 8d, shows that these elongated cells possess very long cytoplasmic extensions, linking up adjacent cells and extending over the underlying layer of flattened mesothelial cells.

A very interesting phenomenon was observed on time-lapse video microscopy. By following a group of cells over several minutes it was seen that certain mesothelial cells actually increased their spreading capacity, so that these cells had a larger surface area under shear stress. Eskin *et al.* [14] reported a similar phenomenon for EC derived from the bovine aorta. Using a mock circulatory loop, giving maximum shear stress of 6.3 dynes/cm² for turbulent flow and

4.6 dynes/cm² for laminar flow, they described cell size increase under these conditions.

The control cell population, HUVEC, demonstrated a markedly different behaviour of that of HOMES. Confluent HUVEC cultures were sheared off the substratum (glass + / - FN) just like a carpet, that is, in one layer. Only occasional foci could be seen which remained on the substratum. Fig. 9a shows one such focus with well spread flattened endothelial cells. In other cases, cell elongation with cytoplasmic retraction was evident (Fig. 9b). Of further interest is the finding that *subconfluent* cultures of HUVEC were much more shear-resistant than confluent monolayers of HUVEC. We conclude from this that the strength of cell-cell contacts between endothelial cells in the confluent state are higher than the strength of cell-substratum contact. It is as yet unclear, which component of the latter is responsible, as cell-substratum adhesion has two levels, namely the adhesive bonds between the cells and the underlying glycoprotein matrix and those between the glycoprotein matrix and the artificial substratum (in this case glass).

Many research groups have used dynamic systems to investigate the effects of shear stress on EC structure and function. Laminar shear stress of 5–10 dynes/cm² can cause a time-dependent change in

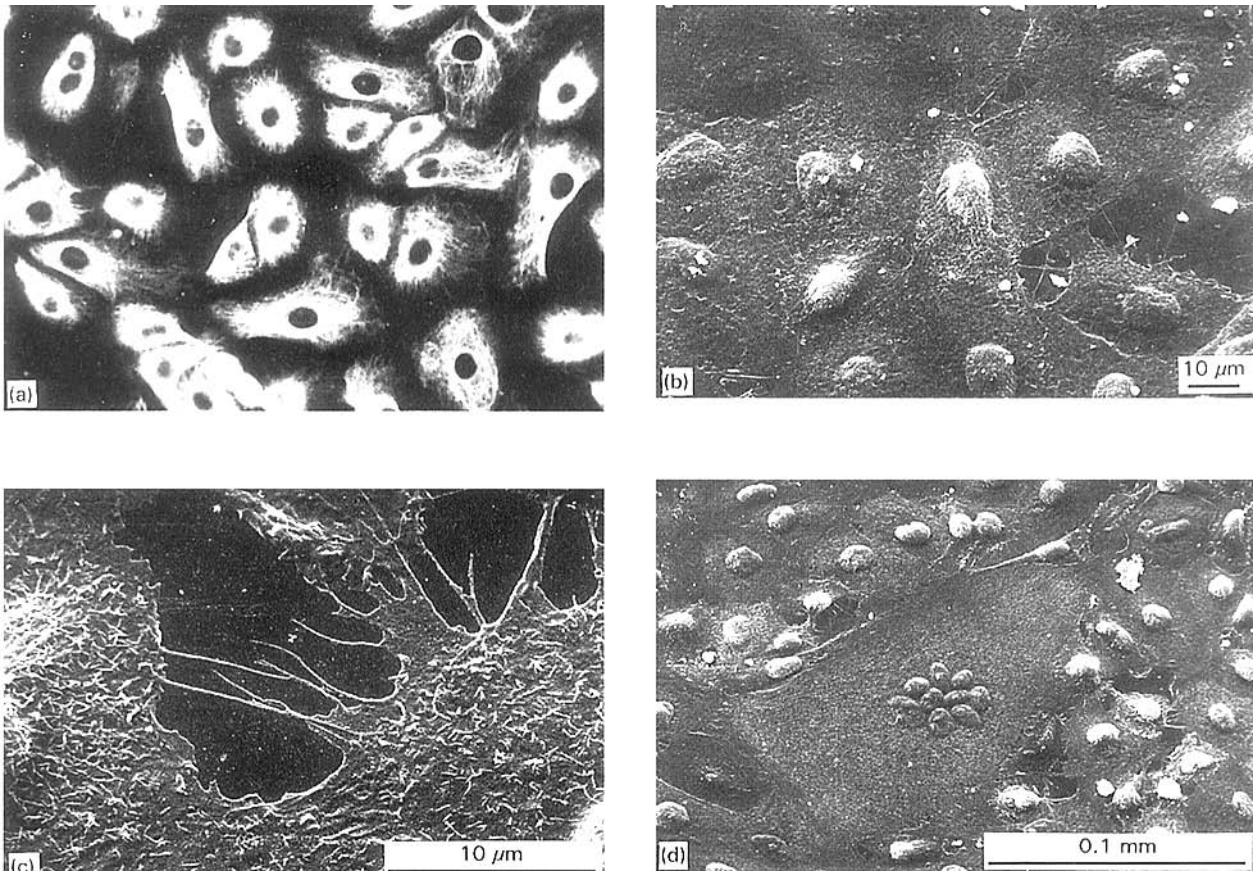

Figure 5 Immunocytochemical and scanning electron microscopical (SEM) characterization of HOMES. (a) Intensive positive immunofluorescent staining of HOMES cytoplasm for cytokeratin; (b) SEM of HOMES, showing typical polygonal cell morphology; (c) SEM of HOMES to show microvillous processes on the surface of the cells; (d) Multinucleated giant cell, providing evidence of the macrophage characteristics of the HOMES.

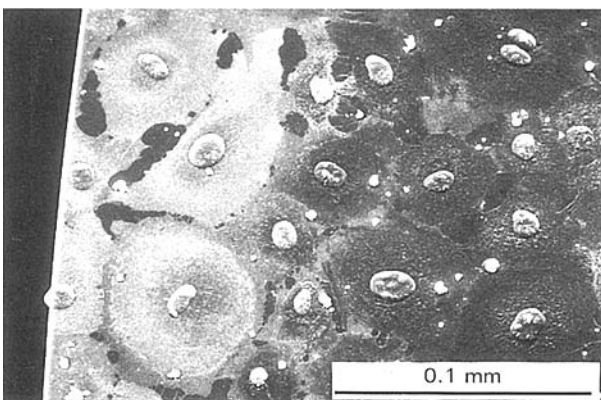

Figure 6 SEM of the laser-cut edge of the HOMES-seeded glass disc.

cell shape, with the EC becoming spindle-shaped and orientated parallel to the direction of flow [18]. Laminar shear stress of as low as 2 dynes/cm² for 3 h leads to the development of marked cytoskeletal actin filament bundles [16]. Microfilament, but not microtubule organization has been shown to be essential to adhesion [19]. Other studies indicate that shear stress applied to EC cultures leads to increased DNA synthesis [20], increased production of prostacyclin [21], increased mRNA levels of t-PA [22] and

platelet-derived growth factor (PDGF; [23]), as well as down-regulation of proteoglycan [24] and fibronectin synthesis [25].

In addition to these basic studies on shear stress and EC behaviour there are also more applied investigations, involving flow systems on EC-seeded vascular graft materials. Schneider and colleagues [26] performed experiments on ePTFE and Dacron grafts of 4 mm diameter, coated with bovine dermal collagen type I before seeding with HUVEC. They described the formation of confluent monolayers after 2 h of incubation in an *in vitro* perfusion system using a flow rate of 15 ml/min. At higher flow rates there was loss of adherent cells. Thus, at 200 ml/min retention of EC was 83% and 76% on Dacron and ePTFE, respectively. Greisler *et al.* [27] used 4 mm polyester elastomer (Hytrel®) prostheses, pre-treated with fibronectin and seeded with canine EC. They described relatively minor losses of EC under perfusion conditions, especially during the first 15 min. Even under perfusion pressure of 200/100 mm Hg, mean flow of 195 ml/min and a resulting shear rate of 520/s, 90% EC adherence was observed after 2 h of shear. Similar conclusions about the beneficial effects of fibronectin pre-coating of Hytrel and ePTFE for the strength of EC attachment were drawn by Kesler *et al.* [28].

By comparison, Kadletz *et al.* [29] described almost complete loss of seeded EC after 24 h of shear stress of

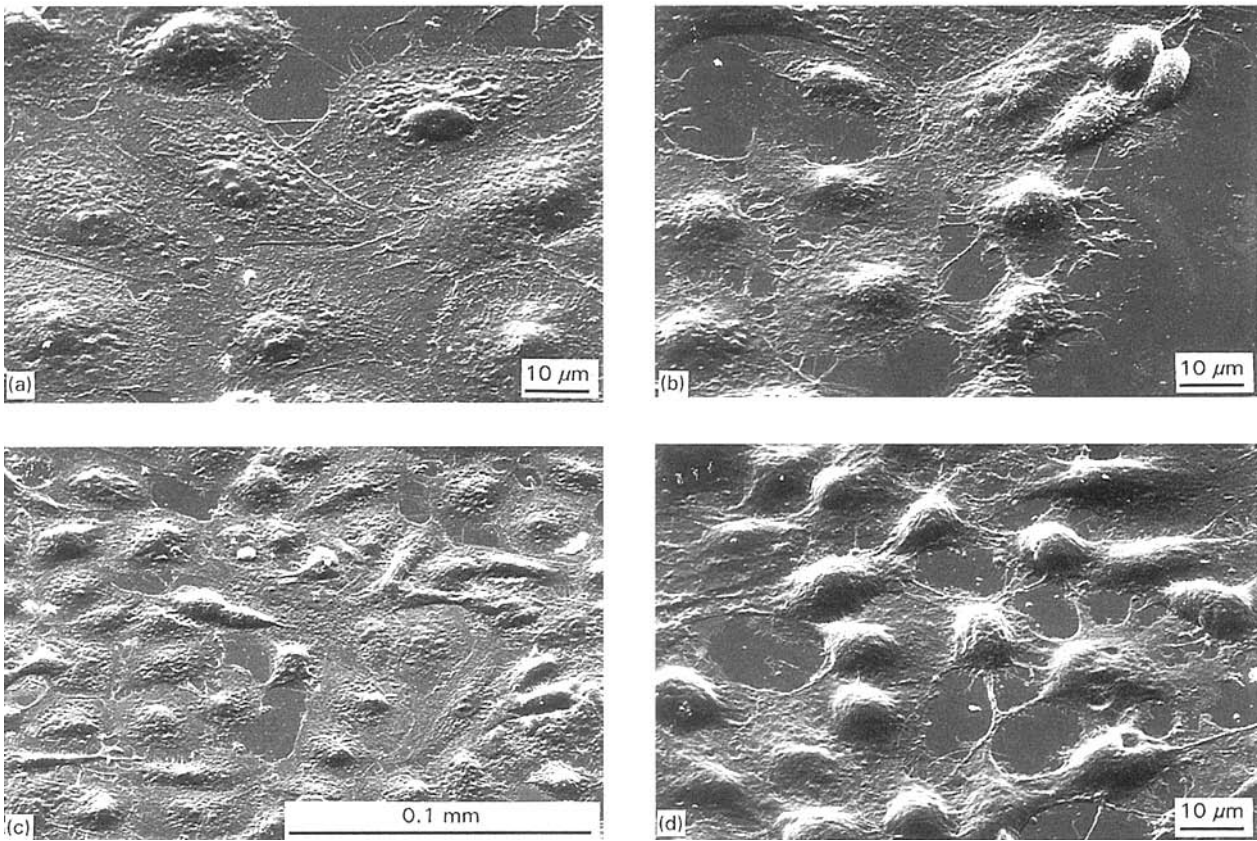

Figure 7 SEM appearance of shear stress-treated HOMES cultures after various times and in different topographical locations within the rheometer. (a) 5 min shear stress at periphery. Cells polygonal and generally flat. (b) 5 min shear stress at central region. Raised nuclei and partial cytoplasmic retraction. (c) 15 min shear stress at periphery. Raised nuclei and elongation of cells. (d) 30 min shear stress at central region. Nuclei markedly raised, retraction of cytoplasm and loss of microvilli.

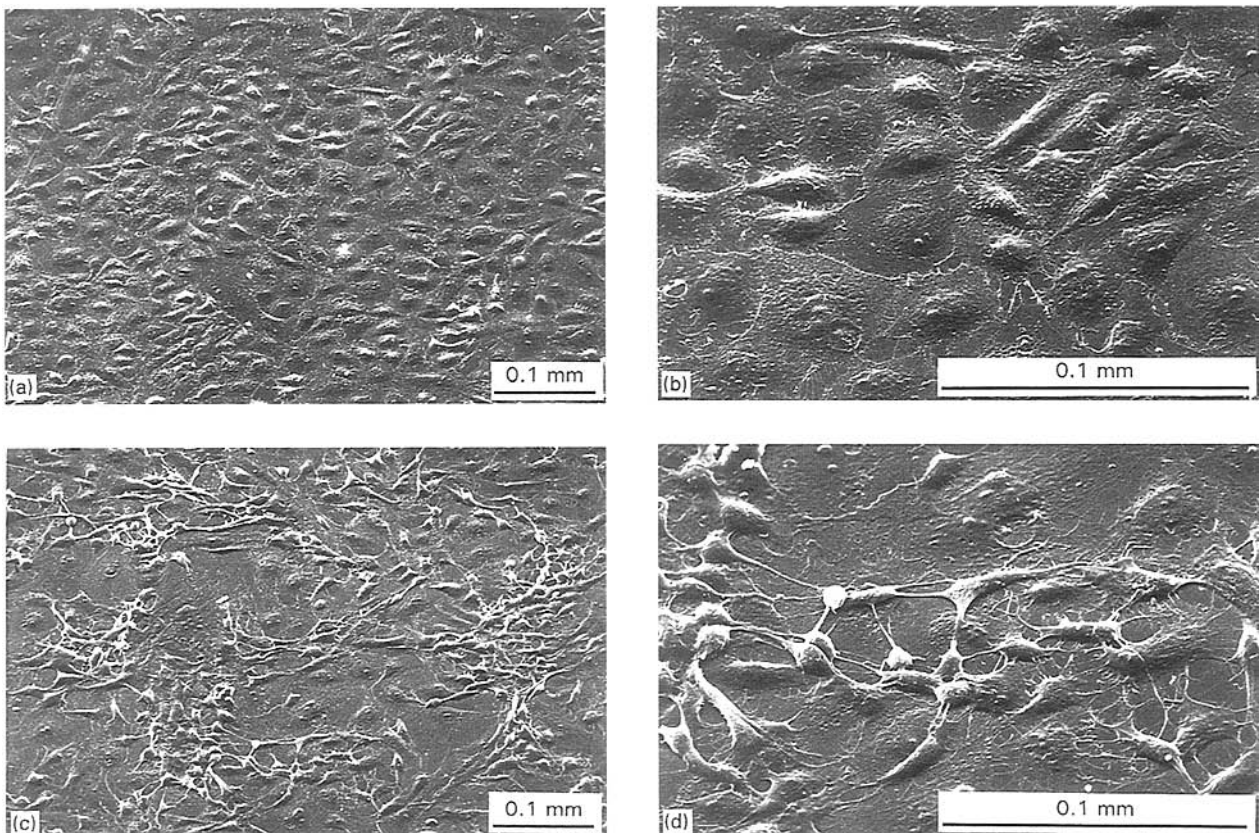

Figure 8 As in Fig. 7, but with evidence of earlier onset of shear stress-associated morphological changes. (a) 5 min shear stress. Cell elongation is apparent. (b) As in (a), however, with clearly raised nuclei, cytoplasmic retraction and cell elongation. (c) 15 min shear stress, resulting in a greater degree of cell elongation. (d) As in (c), illustrating the extent of cytoplasmic retraction.

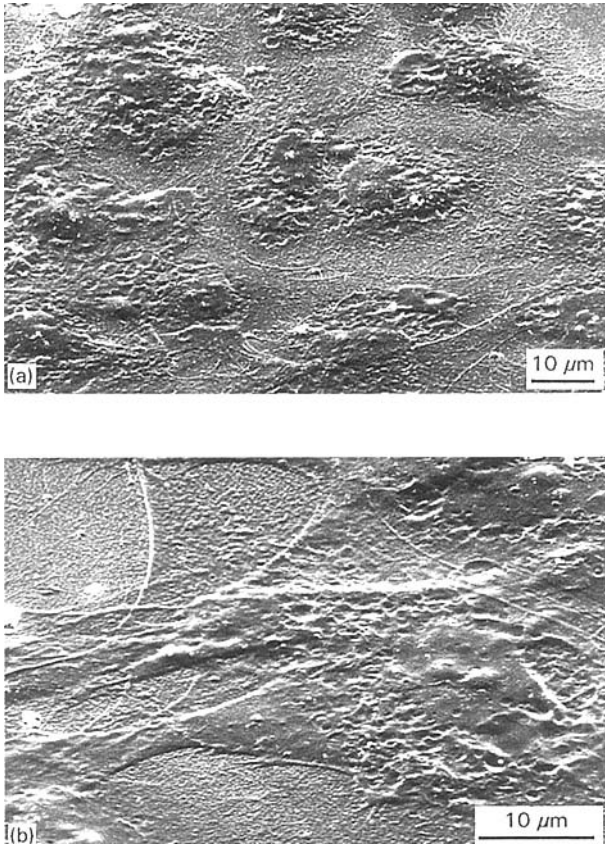

Figure 9 SEM appearance of confluent HUVEC cultures subjected to shear stress of 30 min duration. (a) One of very few cell-covered areas, still showing spread cells. (b) As in (a), however, with evidence of cytoplasmic retraction.

fibronectin-coated ePTFE prostheses. Better results have been obtained by using combinations of pre-coatings. Zilla *et al.* [30] seeded human adult saphenous vein EC (HASVEC) on to PTFE grafts coated with fibrin glue alone or collagen I followed by fibrin glue. In shear stress experiments performed in a mock circulatory loop for 24 h or 48 h they found that fewer cells were detached from the grafts coated with the combination of fibrin glue and collagen type I than those with fibrin glue alone. Sentissi *et al.* [31] described the efficacy of a combined coating of ePTFE using collagen and fibronectin. After seeding with bovine aorta EC and culture for 2 weeks, the grafts were exposed to low (25 ml/min) and high (200 ml/min) flow rates for 1 h. Only minimal loss of EC was observed.

Vohra and colleagues [32] have attempted to simulate more closely the setting in the operating room by performing flow experiments on grafts as early as 90 min after seeding. In a first series of experiments, they compared the efficacy of preclot and fibronectin coatings of ePTFE prostheses using flow rates of up to 300 ml/min ($= 2.6 \text{ dynes/cm}^2$). After 2 h at this highest flow rate, HASVEC retention was of the order of 60% for both coatings, although at lower flow rates, the preclot coating gave better retention than the fibronectin surface. A similar experimental setup was used to investigate HASVEC retention on ePTFE and gelatine-impregnated Dacron (Gelseal®) [33]. The latter gave retention values of approx-

imately 66% after 2 h exposure to a flow rate of 300 ml/min.

Miyata *et al.* [34] have addressed an important issue in this complex field of EC adhesion under shear stress conditions, namely the need to optimize the initial cell density and the time interval after seeding before shear stress is applied. Using fibronectin-coated ePTFE grafts seeded with HASVEC and subjected to an *in vitro* pulsatile flow circuit (90 min), giving a maximal shear stress of 7.4 dynes/cm^2 (of the order of that found in the femoropopliteal arterial system), they investigated post-seeding time intervals of 90 min up to 7 days. Controls were identically treated grafts not exposed to flow. A very interesting finding derived from the experiments using a high initial seeding density (10^5 cells/cm^2). A post-seeding interval of 90 min gave, as expected, poor cell retention (46%). The retention values at 1, 3 and 7 days were 92%, 72% and 42%, respectively, clearly showing that prolonged incubation after high density seeding appears to be detrimental to the success of the seeding method. This elegant series of experiments underlines the importance of using controlled *in vitro* conditions to **optimize** the seeding protocol for a particular cell type as well as the chosen graft material and its coating. This principle applies not only to seeding of EC, but also of HOMES.

The possible use of HOMES as an alternative to EC for vascular graft pre-seeding depends not only on the shear-stress resistance of the cell monolayer, but also on the adoption of desirable elements of the endothelial phenotype. From a theoretical point of view this involves an up-regulation of anti-thrombogenic functions and a concomitant down-regulation of pro-thrombogenic activities. Concerning the production of antithrombogenic substances, van Hinsbergh *et al.* [11] described the ability of HOMES to produce large amounts of t-PA (tissue-type plasminogen activator). Using the same cell type, Takahashi *et al.* [10] reported that HOMES did not produce t-PA *in vitro*, but rather the urokinase-type PA (u-PA), which was demonstrated as antigen, but without detectable activity. This lack of activity was interpreted in the context of the production by HOMES of active plasminogen activator inhibitor (PAI-1). In addition, Takahashi *et al.* showed that HOMES can take up acetylated low density lipoprotein (Ac-LDL) and also produce angiotensin converting enzyme (ACE), two important functions of EC. In their mixed cultures of 10% EC and 60% MES, Latron *et al.* [13] demonstrated that the mixed cultures produced 50-fold more t-PA than HUVEC, although both cultures gave similar production of PAI-1. This indirectly suggests that MES produce very large amounts of t-PA.

Chung-Welch *et al.* [35] did comparative studies on bovine pulmonary microvascular EC and pericardial MES and described close similarities between the two cell types concerning uptake of Ac-LDL and production of ACE and factor VIII related antigen. In a detailed investigation of arachidonic acid metabolism in bovine pericardial MES, Satoh and Prescott [36] reported a marked production of prostacyclin in response to both physiological and pathological

stimuli, including histamine, thrombin and calcium ionophore.

It can be concluded from these studies on *static* culture systems that MES do possess phenotypic properties of the EC. As early as 1984, attempts were made by Clarke *et al.* [37] to seed MES on to vascular prostheses. This was performed on Dacron grafts, subsequently implanted into dogs for 1 month. Later studies in the same *in vivo* model indicated that MES-seeded grafts produced prostacyclin in amounts which increased with implantation time [38]. Further evidence for the ability of MES to maintain fibrinolytic activity *in vivo* has been provided by Louagie *et al.* [39] using mesothelial patches as a venous substitute in dogs.

It is evident that much more research into the regulatory mechanisms of flow on the pro- and anticoagulatory activity of mesothelial cells is required before a clinical application could be considered. However, our investigations indicate that this cell type shows marked shear resistance, a pre-requisite for any future *in vivo* application.

Acknowledgements

The authors wish to express their gratitude to Mr Markus Valdor (FACS), Dr Günter Hollweg and Mr Manfred Bovi (electron microscopy), and Miss Iris Hermanns and Miss Gabriele Pennartz (cell culture) for their invaluable practical assistance and to Professor Christian Mittermayer, Institute of Pathology, RWTH Aachen for his encouragement and support. We also wish to acknowledge the generous support from the Commission of the European Communities (BRITE/EURAM, grant P2217) and the Ministry of Science and Education of the State of Rhineland-Palatinate.

References

1. M. B. HERRING, A. L. GARDNER and J. GLOVER, *Surgery* **84** (1978) 498.
2. P. ÖRTENWALL, H. WADENVIK, J. KUTTI and B. RISBERG, *J. Vasc. Surg.* **11** (1990) 403.
3. C. J. KIRKPATRICK, D. MÜLLER-SCHULTE, M. ROYÉ, G. HOLLWEG, C. GOSSEN, H. RICHTER and C. MITTERMAYER, *Cells & Materials* **1** (1991) 93.
4. L. M. GRAHAM, W. E. BURKEL, J. W. FORD, D. W. VINTER, R. H. KAHN and J. C. STANLEY, *Surgery* **91** (1982) 550.
5. A. W. CLOWES, T. R. KINKMAN and M. A. REIDY, *Amer. J. Pathol.* **123** (1986) 220.
6. S. SHINDO, A. TAKAGI and A. D. WHITTEMORE, *J. Vasc. Surg.* **6** (1987) 325.
7. R. FASOL, P. ZILLA, M. DEUTSCH, M. GRIMM, T. FISCHLEIN and G. LAUFER *ibid.* **9** (1989) 432.
8. P. A. KERN, A. KNEDLER and R. H. ECKEL, *J. Clin. Invest.* **71** (1983) 1822.
9. K. TAKAHASHI, Y. SAWASAKI, T. GOTO, J. HATA and K. MUKAI, *In Vitro Cell. Develop. Biol.* **25** (1989) 109.
10. K. TAKAHASHI, J. -C. HATA, K. MUKAI and Y. SAWASAKI, *ibid.* **27A** (1991) 542.
11. V. W. M. VAN HINSBERGH, T. KOOISTRA, M. A. SCHEFFER, J. H. VAN BOCKEL and G. N. P. VAN MUIJEN, *Blood* **75** (1990) 1490.
12. B. PÖTZSCH, J. GRULICH-HENN, R. RÖSSING, D. WILLE and G. MÜLLER-BERGHHAUS, *Lab. Invest.* **63** (1990) 841.

13. Y. LATRON, M. C. ALESSI, F. GEORGE, F. ANFOSSO, P. PONCELET and I. JUHAN-VAGUE, *Thromb. Haemostas.* **66** (1991) 361.
14. F. BITTINGER, *personal communication* (unpublished results).
15. C. J. KIRKPATRICK, B. D. BUELTMANN and H. GRULER, *Amer. J. Pathol.* **118** (1985) 15.
16. R.-P. FRANKE, M. GRÄFE, H. SCHNITTLER, D. SEIFFGE and C. MITTERMAYER, *Nature* **307** (1984) 648.
17. S. G. ESKIN, H. D. SYBERS, W. O'BANNON and L. T. NAVARRO, *Artery* **10** (1982) 159.
18. C. F. DEWEY Jr, S. R. BUSSOLARI, M. A. GIMBRONE Jr and P. F. DAVIES, *J. Biomech. Eng.* **103** (1981) 177.
19. A. R. WECHEZAK, T. N. WIGHT, R. F. VIGGERS and L. R. SAUVAGE, *J. Cell. Physiol.* **139** (1989) 136.
20. J. ANDO, T. KOMATSUDA, C. ISHIKAWA and A. KAMIYA, *Biorheology* **27** (1990) 675.
21. J. A. FRANGOS, S. G. ESKIN, L. V. McINTIRE and C. L. IVES, *Science* **227** (1985) 1477.
22. S. L. DIAMOND, J. B. SHAREFKIN, C. DIEFFENBACH, K. FRASIER-SCOTT, L. V. McINTIRE and S. G. ESKIN, *J. Cell. Physiol.* **143** (1990) 364.
23. H. -J. HSIEH, N. -Q. LI and J. A. FRANGOS, *Amer. J. Physiol.* **260** (1991) H642.
24. J. GRIMM, R. KELLER and P. G. DE GROOT, *Thromb Haemostas.* **60** (1988) 437.
25. A. GUPTE and J. A. FRANGOS, *In Vitro Cell. Develop. Biol.* **26** (1990) 57.
26. P. A. SCHNEIDER, S. R. HANSON, T. M. PRICE and L. A. HARKER *Surgery* **103** (1988) 456.
27. H. P. GREISLER, E. D. ENDEAN, J. J. KLOSAK, J. ELLINGER, S. C. HENDERSON, S. M. PHAM, S. J. DURHAM, D. P. SHOWALTER, J. LEVINE and H. S. BOROVETZ, *Arch. Surg.* **124** (1989) 429.
28. K. A. KESLER, M. B. HERRING, M. P. ARNOLD, J. L. GLOVER, H. -M. PARK, M. N. HELMUS and P. J. BENDICK, *J. Vasc. Surg.* **3** (1986) 58.
29. M. KADLETZ, R. MOSER, P. PREISS, P. ZILLA and R. FASOL, *Thorac. Cardiovasc. Surg.* **35** (1987) 143.
30. P. ZILLA, R. FASOL, M. KADLETZ, P. PREISS, P. GROSCURTH, H. SHIMA, S. TSANGARIS, R. MOSER, C. HEROLD, A. GRIESMACHER, G. MOSTBECK, M. DEUTSCH and E. WOLNER, in "Endothelialization of vascular grafts", edited by P. P. Zilla, R. D. Fasol and M. Deutsch (S. Karger, Basel, 1987) p. 195.
31. J. M. SENTISSI, K. RAMBERG, T. F. O'DONNELL Jr, R. J. CONNOLLY and A. D. CALLOW, *Surgery* **99** (1986) 337.
32. R. K. VOHRA, G. J. L. THOMSON, H. SHARMA, H. M. H. CARR and M. G. WALKER, *Eur. J. Vasc. Surg.* **4** (1990) 33.
33. R. VOHRA, G. J. L. THOMSON, H. M. H. CARR, H. SHARMA and M. G. WALKER, *Surgery* **111** (1992) 210.
34. T. MIYATA, M. S. CONTE, L. A. TRUDELL, D. MASON, A. D. WHITTEMORE and L. K. BIRINYI, *J. Surg. Res.* **50** (1991) 485.
35. N. CHUNG-WELCH, W. F. PATTON, G. P. A. YEN-PATTON, H. B. HECHTMAN and D. SHEPRO, *Differentiation* **42** (1989) 44.
36. K. SATOH and S. M. PRESCOTT, *Biochim. Biophys. Acta.* **930** (1987) 283.
37. J. M. F. CLARKE, R. M. PITTILO, L. J. NICHOLSON, N. WOOLF and A. MARSTON, *Brit. J. Surg.* **71** (1984) 492.
38. H. A. BULL, R. M. PITTILO, J. DRURY, J. G. POLLOCK, J. M. F. CLARKE, N. WOOLF, A. MARSTON and S. J. MACHIN, *ibid.* **75** (1988) 671.
39. Y. LOUAGIE, A. LEGRAND-MONSIEUR, C. REMACLE, P. MALDAGUE, L. LAMBOTTE and R. PONLOT, *Res. Exp. Med.* **186** (1986) 239.

Received 5 May 1995

and accepted 29 June 1995